

MORGAN PRODUCTS

PNEUMATIC CHEMICAL PUMPS FOR THE GAS AND OIL INDUSTRIES

Parts List Model DG55-6V

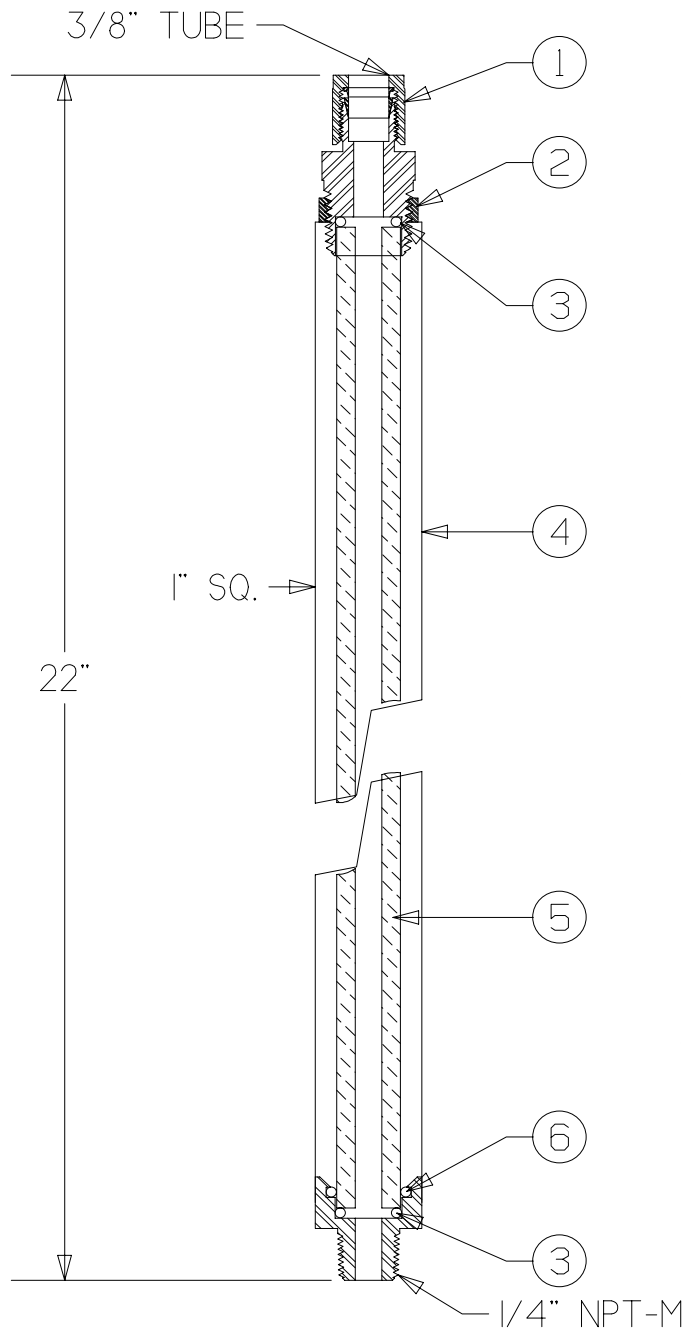

NO	NAME	PART NO.	MATERIAL
1	Tube Fitting Adapter	DG55-3	316 SS
2	Lock Nut	DG55-2	Plated Steel
3	O-Ring Seal (2)	D25-PVC-12/6	Viton / Buna-N
4	Housing	DG55-4	303 SS
5	Gauge Glass	DG55-1	Pyrex
6	O-Ring Seal	DG55-6	Viton / Buna-N

INSTALLATION INSTRUCTIONS

The DG55-6V is for use with chemical injectors with volumes up to 2.5 gal. / hr. (9.5 ℓ / hr.)
 Install a tee in the suction line to the chemical injector.
 Install a 1/4" npt block valve in tee.
 Install DG55-6V in block valve and connect 3/8" tube vent to tank or vent higher than storage tank.

OPERATION INSTRUCTIONS

Open block valve under DG55-6V. Close valve from chemical tank when DG55-6V is full.
 Continue pumping from DG55-6V to check your injection rate. Adjust as needed.
 Close block valve and reopen tank supply. When used on a 55 gallon drum, the block valve can be left open and used as a level gauge.

MORGAN PRODUCTS INC. 28103 Ave. Stanford / Valencia, CA 91355

(661)257-3022 - (800)421-8910 - FAX (661)257-3385 - www.morganproducts.com - E-Mail info@morganproducts.com