

MORGAN PRODUCTS

PNEUMATIC CHEMICAL PUMPS FOR THE GAS AND OIL INDUSTRIES

MODEL 125DS-TR2

AIR ACTUATED POSITIVE DISPLACEMENT PUMP

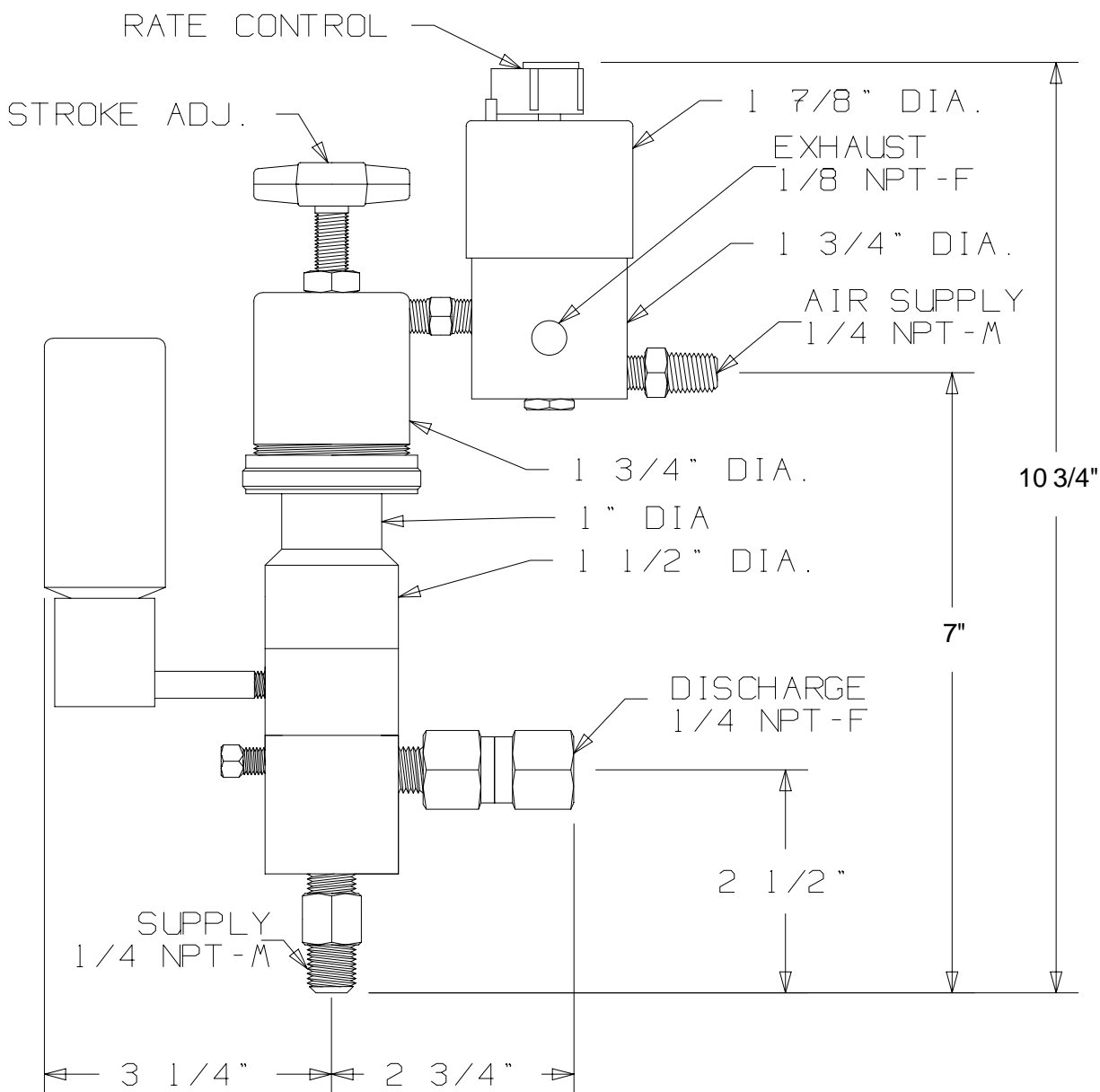

MODEL (WITH TIMER)	PUMP DISPLACEMENT	PUMP RATIO	STROKE LENGTH in. - cm.	CONNECTIONS ALL NPT INPUT / OUTPUT	MAXIMUM DISCHARGE PSI - BAR	OUTPUT PER HOUR GAL. / LTS.
125DS-TR2	.8 cc	31:1	1 - 2.54	1/4 - M / 1/4 - F	4650 - 320	.06 - .63 / .24 - 2.4

MORGAN PRODUCTS INC. 28103 Ave. Stanford / Valencia, CA 91355

(805) 257-3022 - (800) 421-8910 - FAX (805) 257-3385

www.morganproducts.com - E-Mail info@morganproducts.com

MORGAN PRODUCTS

PNEUMATIC CHEMICAL PUMPS FOR THE GAS AND OIL INDUSTRIES

Parts List Model 125DS

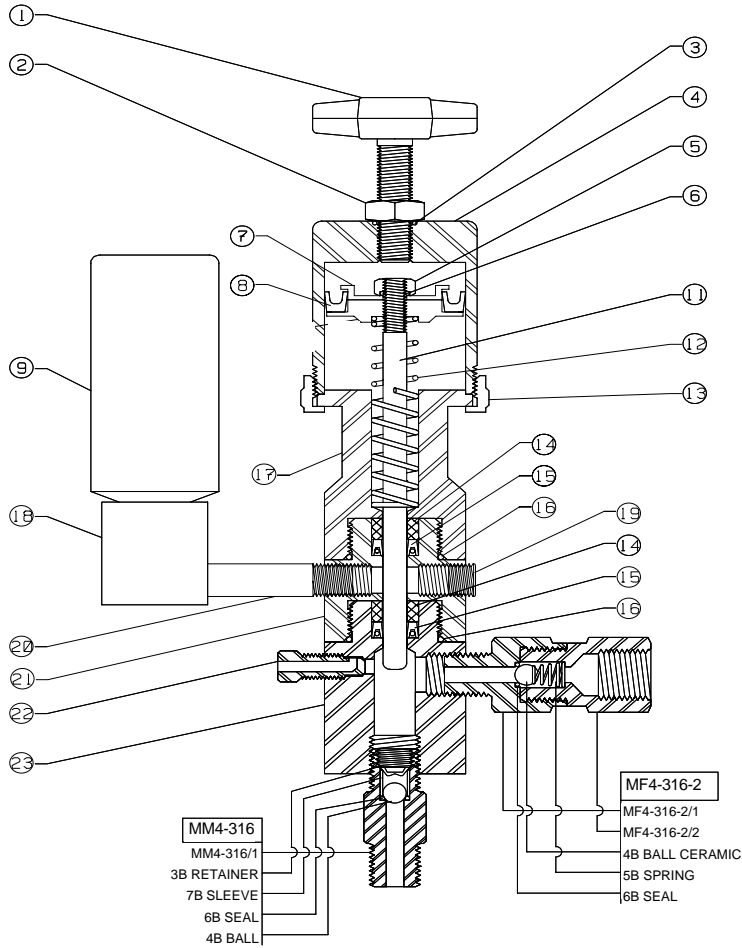

NO	NAME	PART NO.
1	Stroke Adjuster	100-1
2	Locknut	100-2
3	O-Ring Seal	100-3 *
4	Air Chamber	100-4
5	Piston Locknut	100-7
6	O-Ring Seal	100-11 *
7	Piston	100-8
8	Piston Seal	100-9 *
9	2oz. Oil	100-24
10	Not Used	
11	Plungers:	
	17-4 TN Standard	100-65 *
	Optional	
	316 SS	125-67
	Carpenter 20	100-68
12	Return Spring	100-13 *
13	Air Chamber Ring	100-5
14	Back Up Ring	100-19 *(2)
15	Pressure Seals:	
	TG Standard	100-20 +(2)
	Optional	
	Buna- N	100-20B
	Viton	100-20V
	Fluoraz	100-20F
16	O-Ring	100-21 +(2)
17	Oil Chamber	100-14
18	Reservoir	3000-25
19	1/8 NPT Plug	5000-38
20	Nipple	100DS-32
21	Double Seal Body	125-64
22	Bleeder Plug	125-22
23	Fluid Chamber	125-23
	1oz. Grease	*
	Repair Kits:	
	17-4 TN Plunger	100-70
	316 SS Plunger	125-70
	Seal Sets:	
	TG	100-48
	Buna- N	100-48B
	Viton	100-48V
	Fluoraz	100-48F

INSTALLATION INSTRUCTIONS

1. Discard all red plastic closures.
2. Connect suction check valve, to a gravity fed chemical source.
3. Connect discharge check valve, to process line.
4. Connect a regulated air or gas supply, to the timing relay.
5. Fill oil reservoir with oil provided.
** This must be done BEFORE start up.**
6. Open bleeder valve until chemical flows from bleeder.
7. Set regulator at 10 to 15 psi ABOVE the pressure required.
(See discharge pressure graph).
8. Set cycle rate in strokes per minute.
(See volume graph)

* = Included in Repair Kit
+ = Included in Seal Set

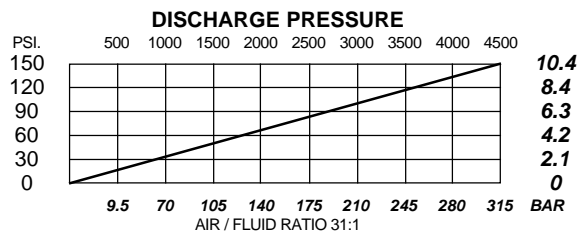
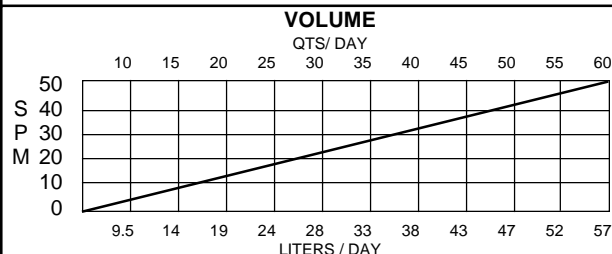

MORGAN PRODUCTS INC. 28103 Ave. Stanford / Valencia, CA 91355

(805) 257-3022 - (800) 421-8910 - FAX (805) 257-3385