

MORGAN PRODUCTS

PNEUMATIC CHEMICAL PUMPS FOR THE GAS AND OIL INDUSTRIES
MODEL 425-TR2-SR1S / 435-TR2-SR1S
 AIR ACTUATED POSITIVE DISPLACEMENT PUMP

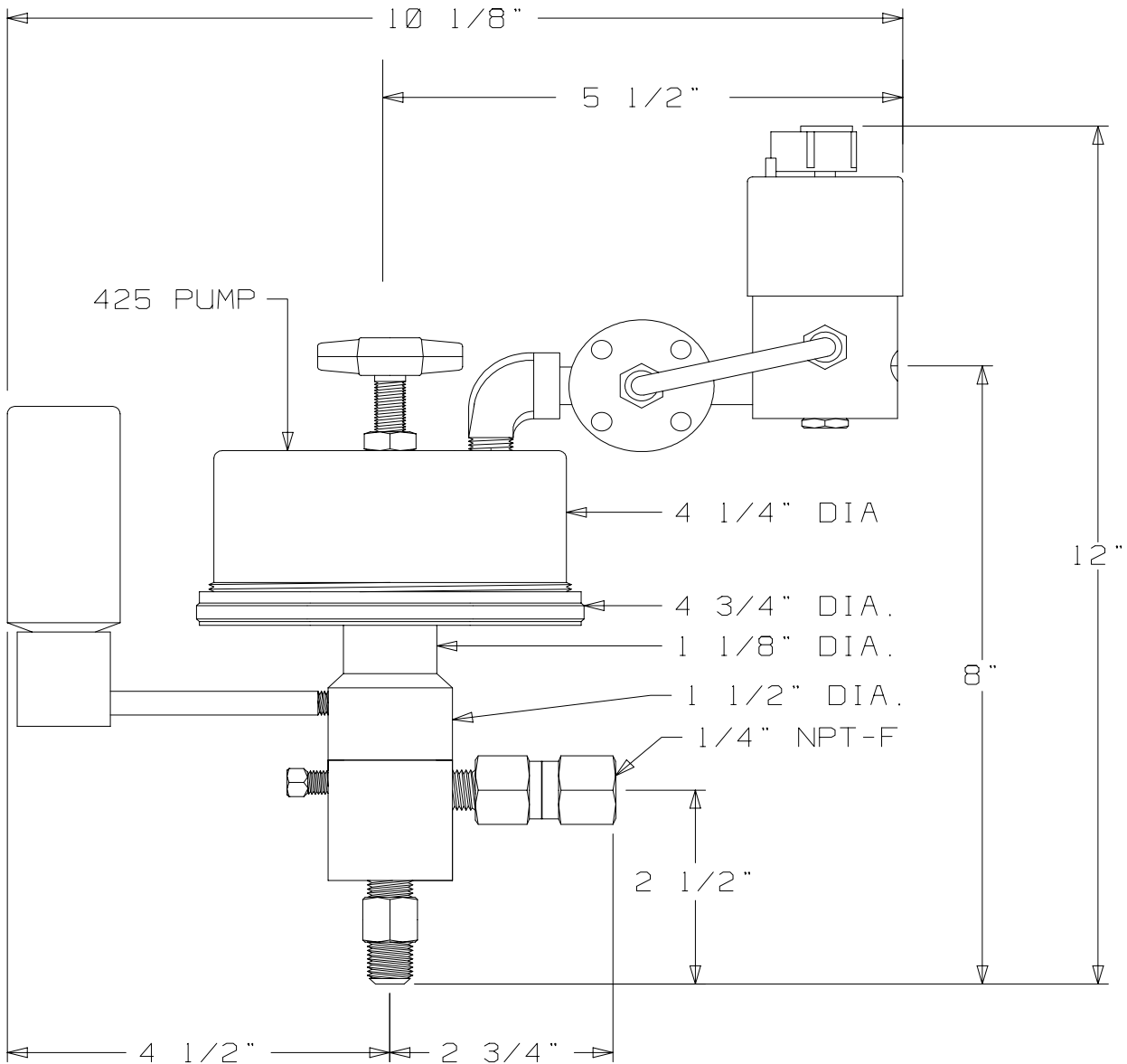

MODEL (WITH TIMER)	DISPLACEMENT	PUMP RATIO	STROKE LENGTH in. - cm.	CONNECTIONS ALL NPT INPUT / OUTPUT	MAXIMUM DISCHARGE PSI - BAR	OUTPUT PER HOUR GAL. / LTS.
425-TR2-SR1S	.8 cc	217:1	1 - 2.54	1/4 - M / 1/4 - F	15000 - 1034	.06 - .63 / .24 - 2.4
435-TR2-SR1S	1.8 cc	97:1	1 - 2.54	1/4 - M / 1/4 - F	10000 - 689	.15 - 1.5 / .55 - 5.5

MORGAN PRODUCTS INC. 28103 Ave. Stanford / Valencia, CA 91355

(805) 257-3022 - (800) 421-8910 - FAX (805) 257-3385

www.morganproducts.com - E-Mail info@morganproducts.com

MORGAN PRODUCTS

PNEUMATIC CHEMICAL PUMPS FOR THE GAS AND OIL INDUSTRIES

Parts List Model 225, 325, 425

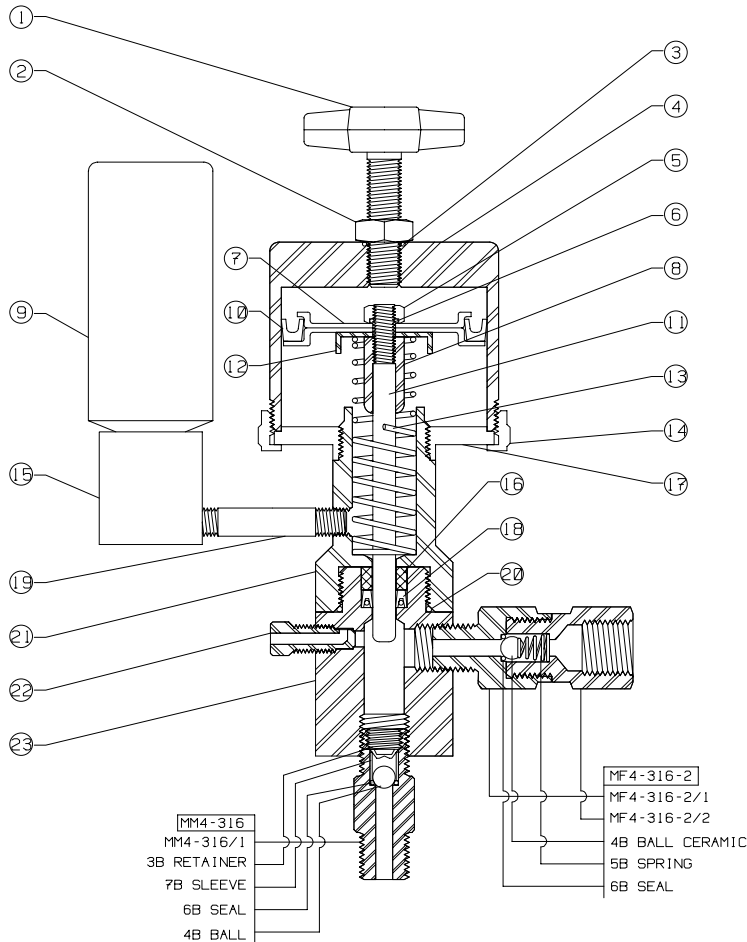

NO	NAME	PART NO.	PUMP MODEL
1	Stroke Adjuster	100-1	ALL
2	Locknut	100-2	ALL
3	O-Ring Seal	100-3	* ALL
4	Air Chambers	200-4 300-4 400-4	200/225 300/325 400/425
5	Piston Locknut	100-7	ALL
6	O-Ring Seal	100-11	* ALL
7	Pistons	200-8 300-8 400-8	200/225 300/325 400/425
8	Spring Guide	200-10	ALL
9	2oz. Oil	100-24	ALL
10	Piston Seals	200-9 300-9 400-9	* 200/225 * 300/325 * 400/425
11	Plungers: 17-4 TN 316 SS Carpenter 20	100-15 125-17 100-18	* ALL Optional Optional
12	Not Used		
13	Return Spring	200-13	* ALL
14	Air Chamber Rings	200-5 300-5 400-5	200/225 300/325 400/425
15	Reservoir	100-25	ALL
16	Back Up Ring	100-19	*+ ALL
17	Faceplates	200-6 300-6 400-6	200/225 300/325 400/425
18	Pressure Seals: TG Buna- N Viton Fluoraz	100-20 100-20B 100-20V 100-20F	*+ ALL Optional Optional Optional
19	Nipples	200-32 300-32 400-32	200/225 300/325 400/425
20	O-Ring Seal	100-21	* ALL
21	Oil Chamber	200-14	ALL
22	Bleeder Plugs	125-22	ALL
23	Fluid Chambers	125-23	ALL
	1oz. Grease		* ALL
	Elbow	400-27	400/425
	Lock Screw	400-28	(2) 400/425
	1/4" Washer	400-29	(2) 400/425
	Repair Kits: 17-4 TN Plunger	200-50 300-50 400-50	200/225 300/325 400/425
	316 SS Plunger	225-50 325-50 425-50	200/225 300/325 400/425
	Seal Sets: TG Buna- N Viton Fluoraz	100-48 100-48B 100-48V 100-48F	ALL ALL ALL ALL

INSTALLATION INSTRUCTIONS

1. Discard all red plastic closures.
2. Connect suction check valve, to a gravity fed chemical source.
3. Connect discharge check valve, to process line.
4. Connect a regulated air or gas supply, to the timing relay.
5. Fill oil reservoir with oil provided.
** This must be done BEFORE start up.**
6. Open bleeder valve until chemical flows from bleeder.
7. Set regulator at 10 to 15 psi ABOVE the pressure required.
(See discharge pressure graph).
8. Set cycle rate in strokes per minute.
(See volume graph)

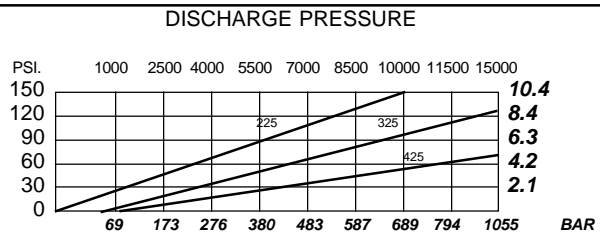
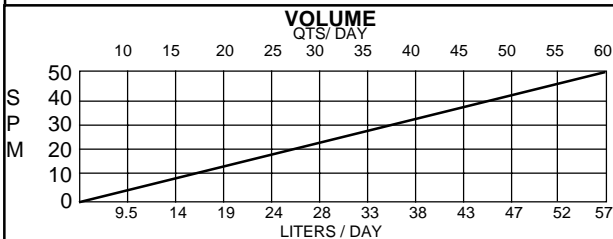

MORGAN PRODUCTS INC. 28103 Ave. Stanford / Valencia, CA 91355

(805) 257-3022 - (800) 421-8910 - FAX (805) 257-3385

* = Included in Repair Kit
+ = Included in Seal Set

MORGAN PRODUCTS

PNEUMATIC CHEMICAL PUMPS FOR THE GAS AND OIL INDUSTRIES

Parts List Model 235, 335, 435

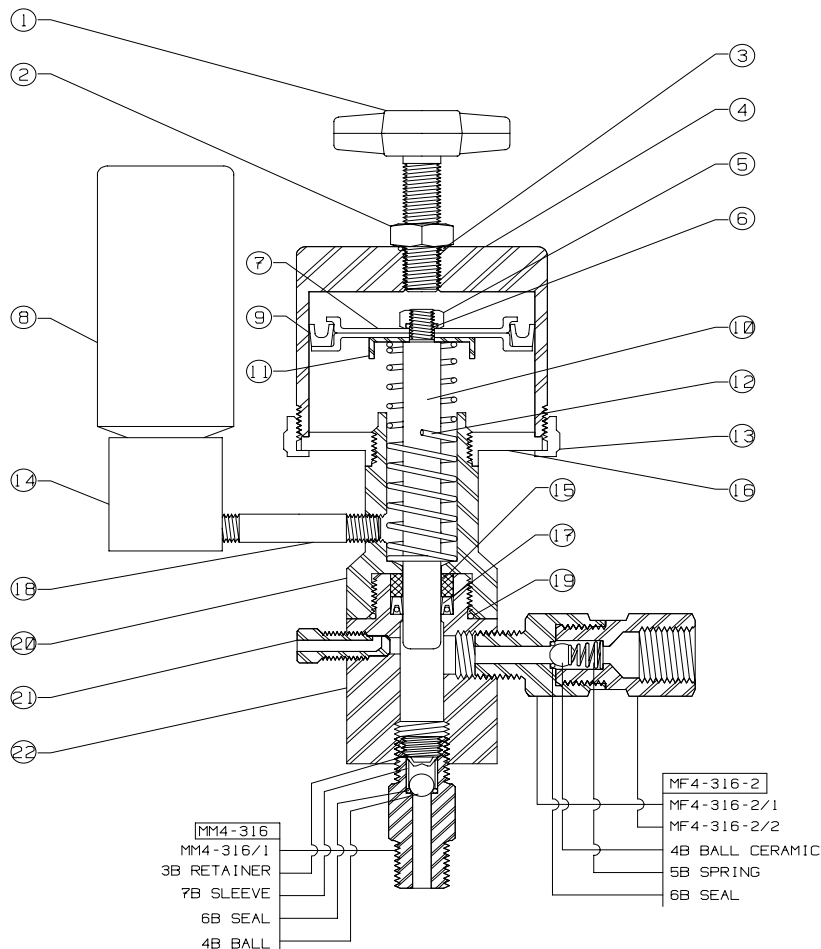

NO	NAME	PART NO.	PUMP MODEL
1	Stroke Adjuster	100-1	ALL
2	Locknut	100-2	ALL
3	O-Ring Seal	100-3 *	ALL
4	Air Chambers	200-4 300-4 400-4	230/235 330/335 430/435
5	Piston Locknut	100-7	ALL
6	O-Ring Seal	100-11 *	ALL
7	Pistons	200-8 300-8 400-8	230/235 330/335 430/435
8	2oz. Oil	100-24	ALL
9	Piston Seals	200-9 300-9 400-9 *	230/235 330/335 430/435
10	Plungers:	230-15 235-17 230-18	ALL Optional Optional
11	Not Used		
12	Return Spring	200-13 *	ALL
13	Air Chamber Rings	200-5 300-5 400-5	230/235 330/335 430/435
14	Reservoir	100-25	ALL
15	Back Up Ring	230-19 **	ALL
16	Faceplates	200-6 300-6 400-6	230/235 330/335 430/435
17	Pressure Seals:	230-20 230-20B 230-20V 230-20F	ALL Optional Optional Optional
18	Nipples	200-32 300-32 400-32	230/235 330/335 430/435
19	O-Ring Seal	100-21 *	ALL
20	Oil Chamber	230-14	ALL
21	Bleeder Plugs	125-22	ALL
22	Fluid Chambers	235-23	ALL
	1oz. Grease	*	ALL
	Elbow	400-27	430/435
	Lock Screw	400-28 (2)	430/435
	1/4" Washer	400-29 (2)	430/435
	Repair Kits:		
	17-4 TN Plunger	230-50 330-50 430-50	230/235 330/335 430/435
	316 SS Plunger	235-50 335-50 435-50	230/235 330/335 430/435
	Seal Sets:		
	TG	230-48	ALL
	Buna-N	230-48B	ALL
	Viton	230-48V	ALL
	Fluoraz	230-48F	ALL

* = Included in Repair Kit
 + = Included in Seal Set

INSTALLATION INSTRUCTIONS

1. Discard all red plastic closures.
2. Connect suction check valve, to a gravity fed chemical source.
3. Connect discharge check valve, to process line.
4. Connect a regulated air or gas supply, to the timing relay.
5. Fill oil reservoir with oil provided.
 ** This must be done BEFORE start up.**
6. Open bleeder valve until chemical flows from bleeder.
7. Set regulator at 10 to 15 psi ABOVE the pressure required.
 (See discharge pressure graph).
8. Set cycle rate in strokes per minute.
 (See volume graph)

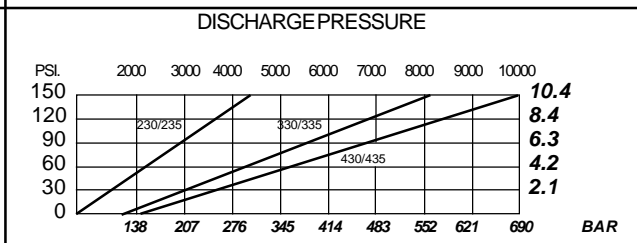
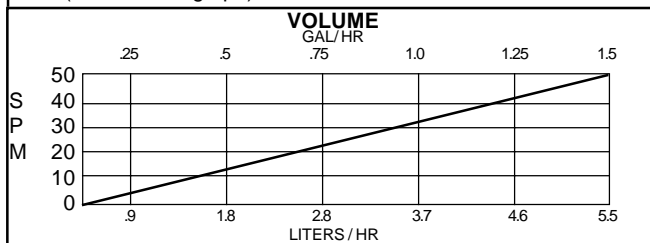

MORGAN PRODUCTS INC. 28103 Ave. Stanford / Valencia, CA 91355

(805) 257-3022 - (800) 421-8910 - FAX (805) 257-3385

Web www.morganproducts.com - E-Mail info@morganproducts.com